

**DETALLE DE VINCULACION DE TABIQUE SANITARIO PLANTA** Esc. 1:25

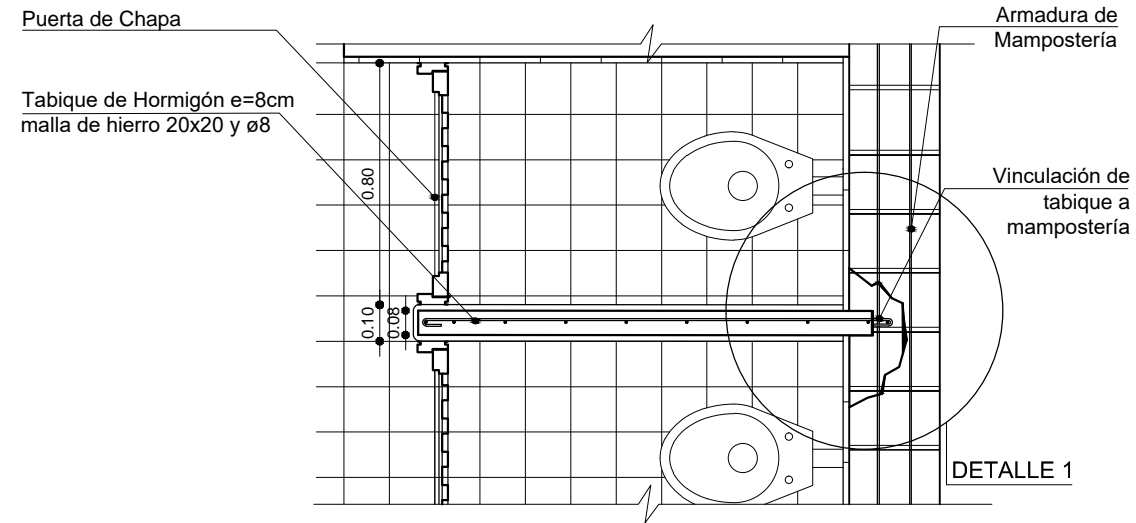

**DETALLE 1**  
Esc. 1:10

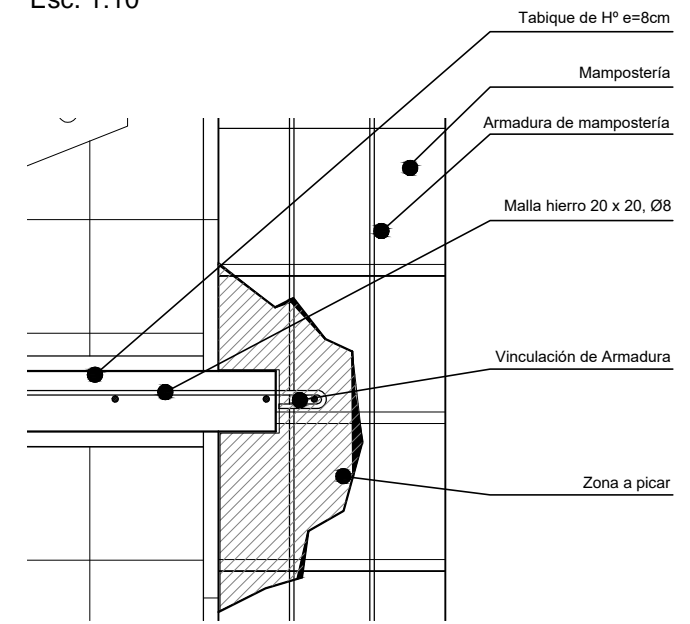

**VISTA LATERAL**  
Esc.:1:25

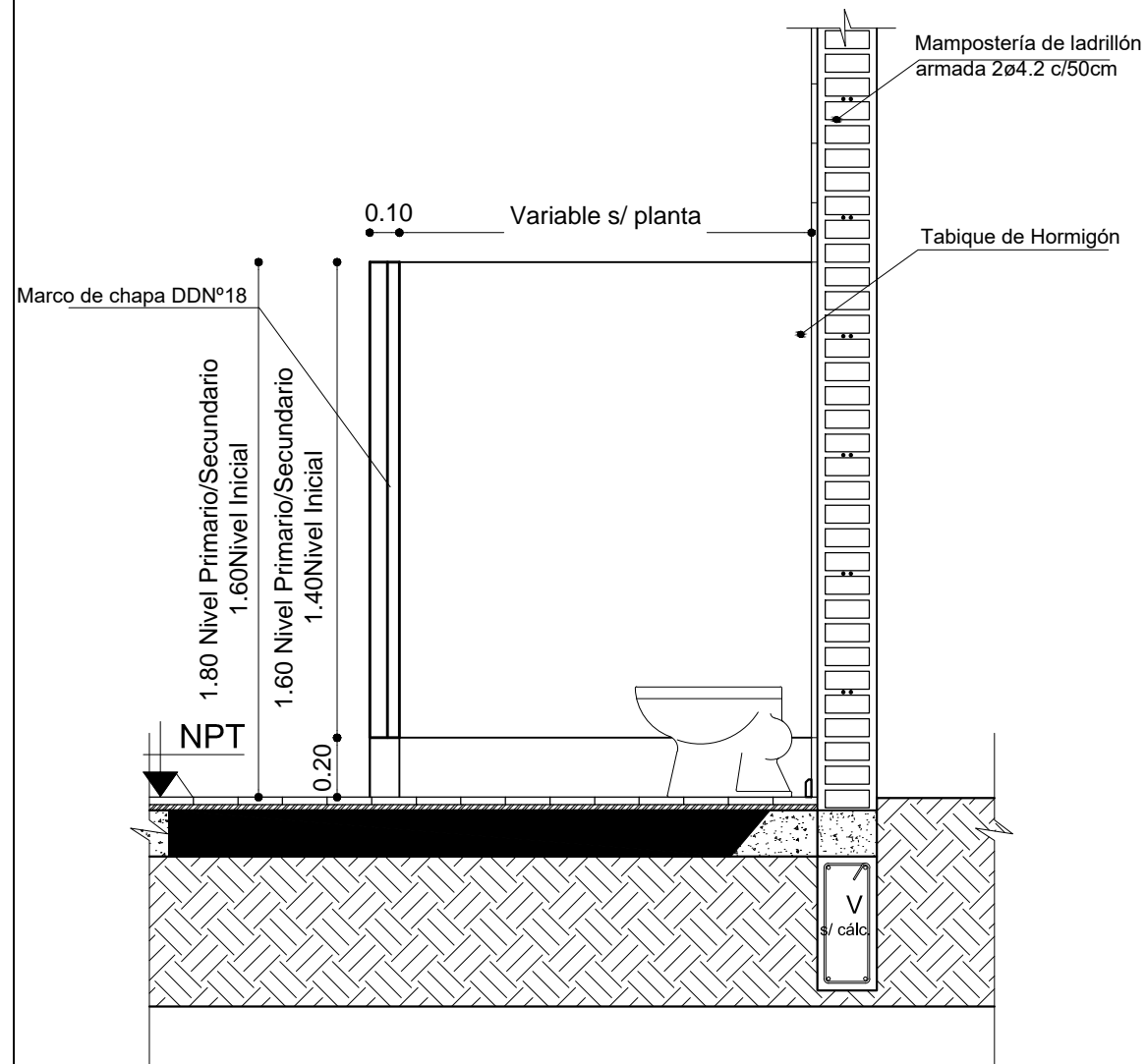

**DETALLE DE VINCULACION DE TABIQUE SANITARIO VISTA** Esc. 1:25

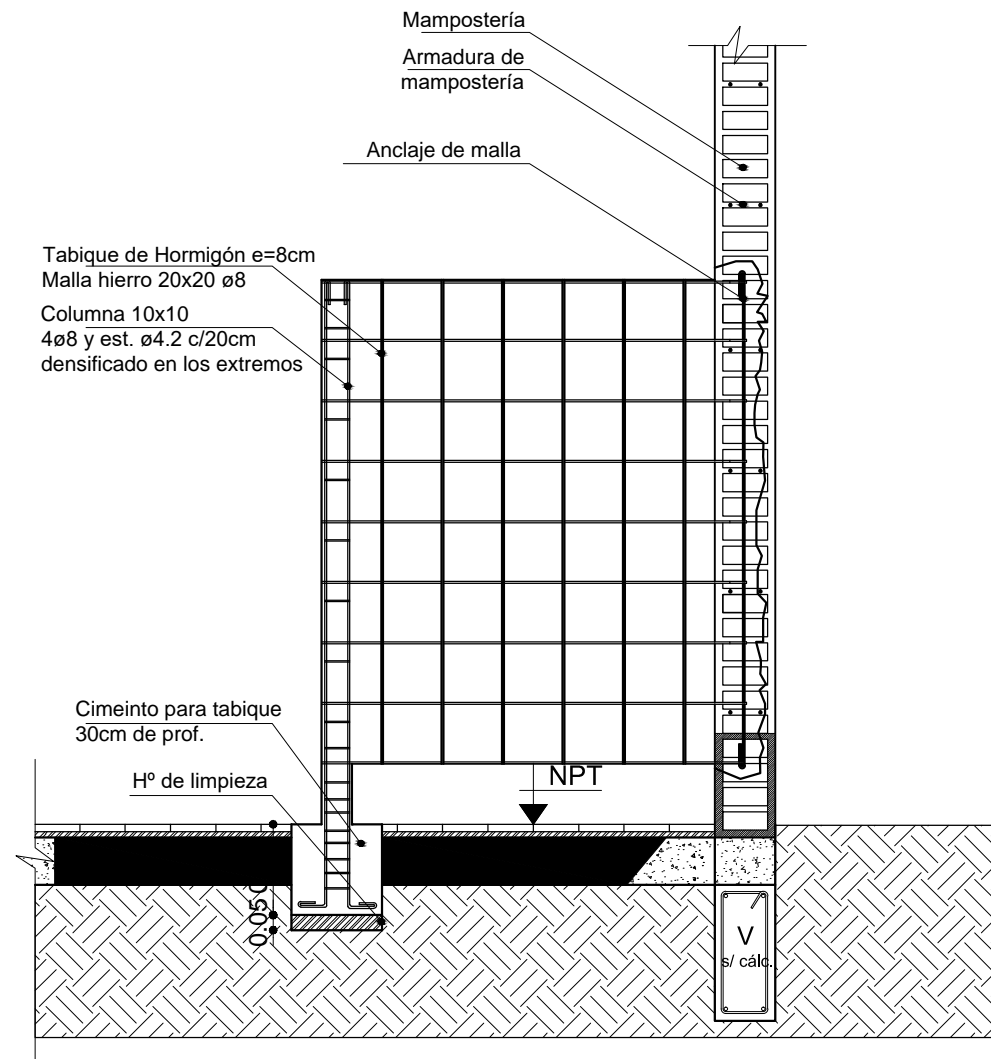

**FONDOS PROVINCIALES**

NOMBRE **Detalle de Tabique Sanitario**

PROYECTISTA **Dirección de Infraestructura Escolar**

FICHA Nº **01**

RESPONSABLE  
Director  
Ing. Oscar Monteros